

Metal Molder™

MAKE
TONS OF
REAL METAL!
FIGURES

CAUTION-ELECTRIC TOY:

Not recommended for children under 8 years of age. As with all electric products, precautions should be observed during the handling and use to prevent electric shock. Immersing this toy in water can cause an electric shock.

CAUTION: Care should be taken when unpacking and assembling. Adult assembly and supervision are necessary.

Danger: To prevent electric shock, do not immerse in water. Wipe clean with damp cloth.

Caution: Use in well ventilated area.

Caution: Contains functional sharp points, handle with care!

Warning: Shock Hazard. Unplug when not in use.

THIS PRODUCT IS LISTED BY
UNDERWRITERS LABORATORIES
INCORPORATED AND BEARS THE MARK



ELECTRICAL RATING:
120 Volt
60 Hz 0.5 Amps
AC only listed

FOR
8+
AGES

INSTRUCTIONS

YOUR METAL MOLDER™ DIE CAST FACTORY MAKES THE COOLEST REAL METAL FIGURES IN MINUTES! IT IS DESIGNED FOR HOURS OF SAFE AND EASY MOLDING. YOUR METAL MOLDER™ DIE CAST FACTORY WILL MAKE YOU HUNDREDS OF THE MOST AWESOME REAL METAL COLLECTIBLE FIGURES IN ALL KINDS OF GREAT THEMES. JUST FOLLOW THESE SIMPLE INSTRUCTIONS AND YOU WILL BE MOLDING METAL IN MINUTES!

YOUR METAL MOLDER™ DIE CAST FACTORY COMES WITH:

- 1 METAL MOLDER™ MACHINE
- 4 PAIRS OF METAL MOLDER™ MOLDS
- 10 SHOTS OF METAL IN PREMEASURED DISPENSERS
- 1/2 OUNCE MOLD POWDER WITH APPLICATOR BRUSH
- 1 FINISHING PLATFORM
- 10 GEMS
- 4 ACCESSORIES
- 1 NECKLACE

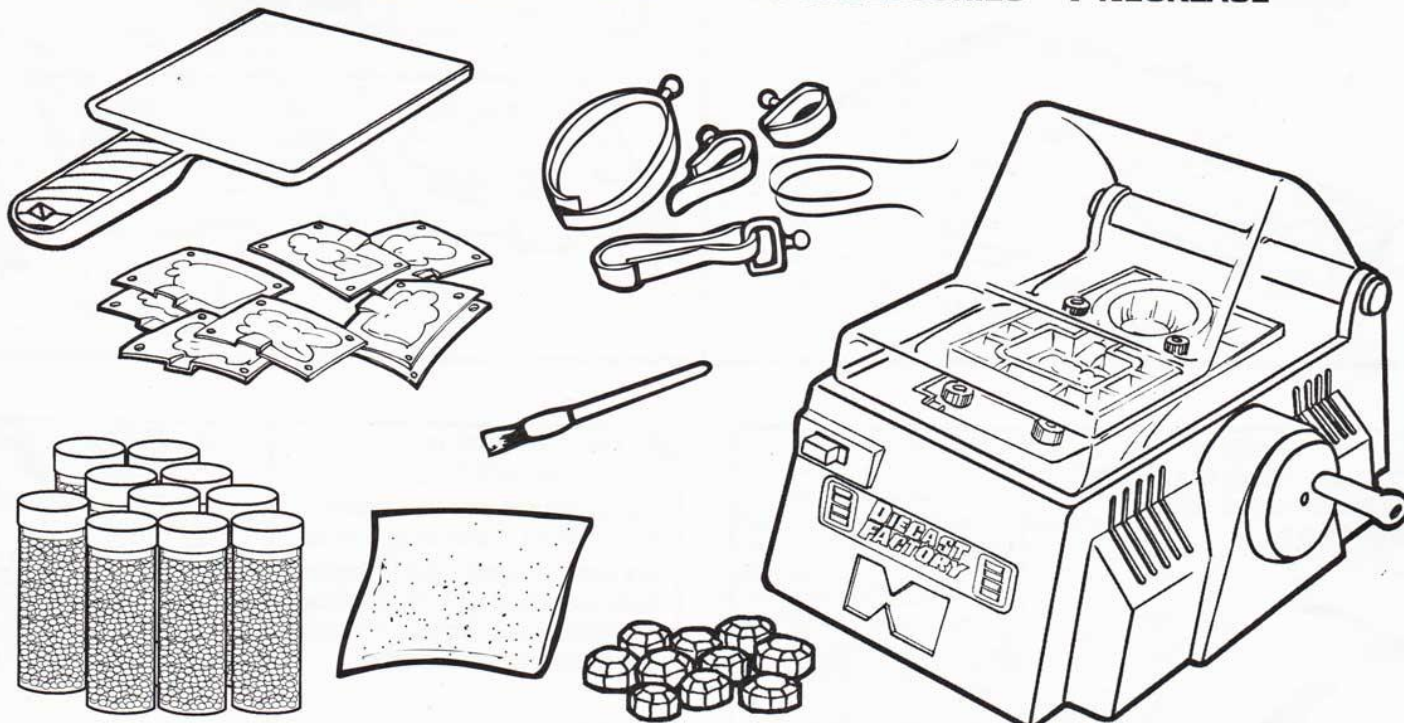

PREPARING TO MOLD:

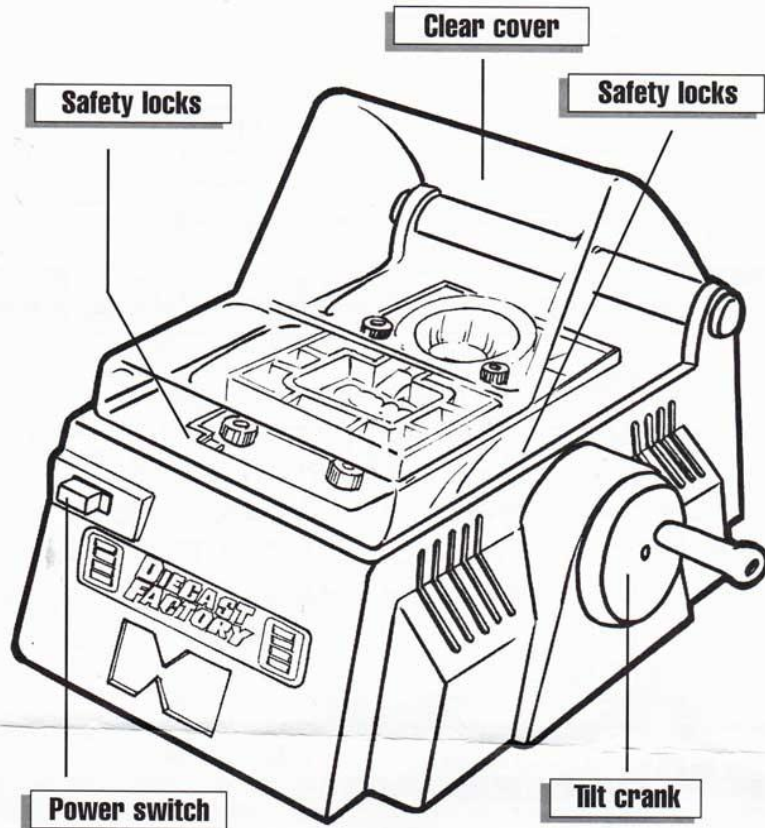

NOTE TO PARENTS:
MOLD HALVES MUST BE CUT APART
USING SCISSOR
AS ILLUSTRATED BELOW.

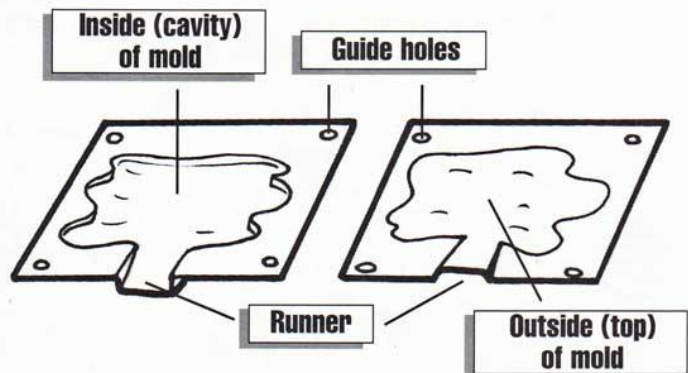
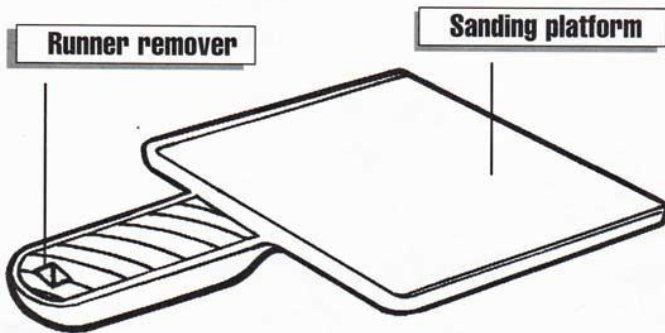
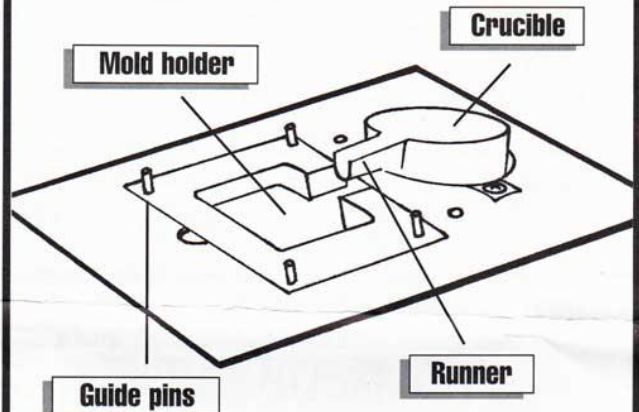
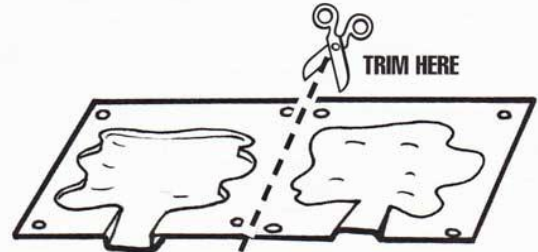

1 PLACE YOUR METAL MOLDER™ DIE-CAST FACTORY ON A SAFE, DRY, FLAT WORKING SURFACE AND HAVE AN ADULT PLUG IT IN.



2 CHOOSE A MOLD FOR THE FIGURE YOU WANT TO CAST.

PLACE THE MOLD ON YOUR WORK SURFACE WITH THE INSIDES OF MOLD HALF FACING UP. WITH YOUR MOLD POWDER AND APPLICATOR BRUSH, LIGHTLY DUST THE INSIDE OF THE MOLD WITH POWDER. SHAKE ANY EXCESS POWDER FROM THE MOLD BEFORE CONTINUING.



3 OPEN THE CLEAR TOP OF YOUR DIE CAST FACTORY (TO DO THIS, THE MACHINE MUST BE COMPLETELY COOL, THE POWER MUST BE OFF AND THE TILTING PLATE MUST BE IN THE FLAT POSITION).

REMOVE THE TOP COVER OF THE TILT PLATE BY UNSCREWING THE 4 THUMB SCREWS AND LIFTING THE PLATE UP (DON'T LOSE THE SCREWS!) THIS WILL EXPOSE THE MOLD HOLDING AREA AND THE CRUCIBLE.

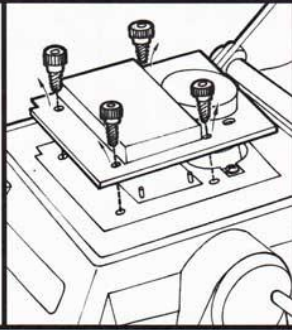

4a PLACE THE BOTTOM HALF OF THE MOLD INTO THE BOTTOM OF THE MOLD HOLDER WITH THE ARROW POINTING TOWARDS THE CRUCIBLE. THE BOTTOM HALF OF THE MOLD GOES INTO THE HOLDER WITH THE INSIDE (CAVITY AREA) FACING UP.

BE SURE THAT THE "RUNNER" AREA OF THE MOLD HALF GOES UNDER THE "RUNNER" AREA OF THE CRUCIBLE AND THAT THE GUIDE POSTS IN THE MOLD HOLDER ARE THROUGH ALL 4 GUIDE HOLES.

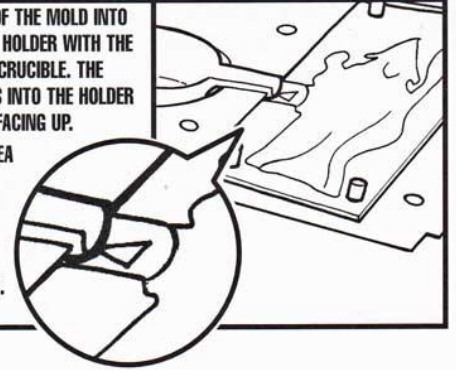

4b PLACE THE TOP HALF OF THE MOLD DIRECTLY ON TOP OF THE BOTTOM HALF IN THE MOLD HOLDER. THE TOP HALF OF THE MOLD GOES IN WITH THE ARROWS FACING THE CRUCIBLE, BUT WITH THE INSIDE (CAVITY AREA) FACING DOWN.

MAKE SURE THE RUNNER AREA OF THE MOLD COMPLETELY COVERS THE TOP OF THE RUNNER ON THE CRUCIBLE AND THAT THE FOUR GUIDE POSTS GO THROUGH THE 4 GUIDE HOLES.

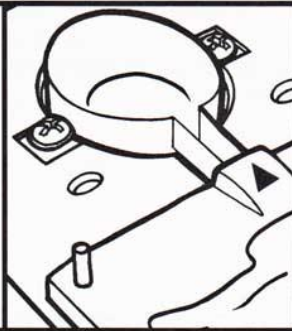

5 TAKE ONE PREMEASURED METAL DISPENSER AND POUR THE CONTENTS INTO THE CRUCIBLE.

YOU MUST NEVER USE MORE OR LESS THAN ONE VIAL OF METAL PELLETS AND YOU MUST NEVER PUT THE PELLETS INTO ANY PART OF THE MACHINE OTHER THAN THE CRUCIBLE.

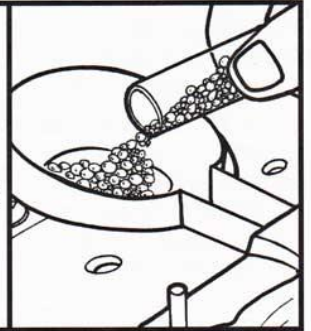

6 ONCE THE MOLD HALVES ARE IN CORRECTLY AND THE CRUCIBLE IS FULL WITH ONE VIAL OF METAL PELLETS, YOU MUST RETURN THE TILT PLATE COVER TO THE MACHINE AND TIGHTEN DOWN THE FOUR THUMB SCREWS COMPLETELY.

THE MACHINE WILL NOT OPERATE UNLESS THIS COVER AND ALL FOUR SCREWS ARE REPLACED!

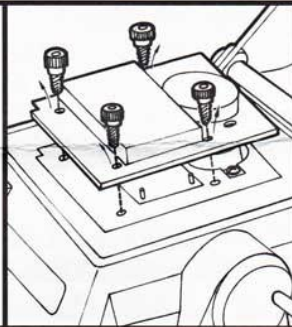

7 CLOSE THE CLEAR TOP TO THE DIE CAST FACTORY FIRMLY, MAKING SURE THAT IT IS COMPLETELY LOCKED DOWN. IF THE CLEAR TOP IS NOT COMPLETELY DOWN, THE MACHINE WILL NOT TURN ON!

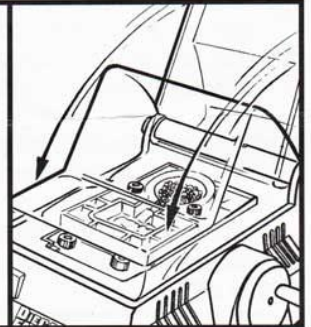

8 TURN THE SWITCH ON THE FRONT OF YOUR MACHINE TO THE "ON" POSITION (TO THE LEFT) AND WATCH THE METAL MELT! IT WILL TAKE APPROXIMATELY 10-12 MINUTES FOR THE METAL TO BE COMPLETELY MOLTEN.

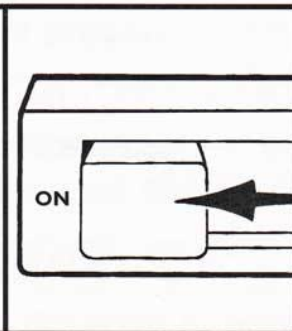

9 PULL THE KNOB ON THE RIGHT SIDE OF THE MACHINE OUT APPROXIMATELY 1/4 INCH AND TURN THE KNOB TOWARD YOU IN A SWIFT MOTION (COUNTER CLOCKWISE) APPROXIMATELY ONE HALF TURN.

THIS WILL FLIP THE TILT PLATE AND POUR THE MOLTEN METAL INTO THE MOLD! YOU SHOULD WAIT 30 SECONDS AFTER THE METAL IS TOTALLY MELTED BEFORE YOU TRY POURING. THE HOTTER THE METAL IS THE BETTER YOUR FIGURE WILL CAST!

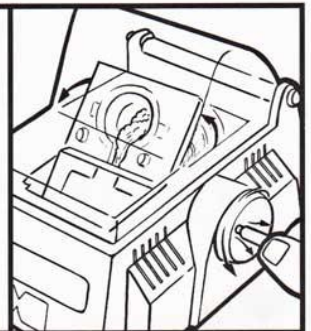

10 TURN THE MACHINE'S POWER SWITCH TO THE "OFF" POSITION.

LEAVE THE KNOB TURNED AND THE TILT PLATE TILTED UNTIL THE UNIT COOLS. THIS WILL TAKE APPROXIMATELY 10-12 MINUTES.

* THE TILT PLATE MUST STAY TILTED WHILE COOLING.

* THE MACHINE WILL NOT OPEN UNTIL IT IS COOL.

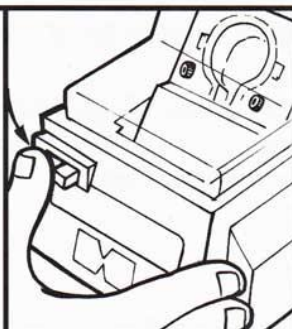

11 Do not open the clear cover until the machine is completely cooled down. After cooling, you can see an arrow pointing to the cool area inside the temperature indication chart. Then, you can crank the tilt plate down by turning away from you (clockwise) approximately 1/2 turn before you can open the clear cover. Make sure the knob snaps back into place after cranking back. The machine will not open unless the knob is locked.

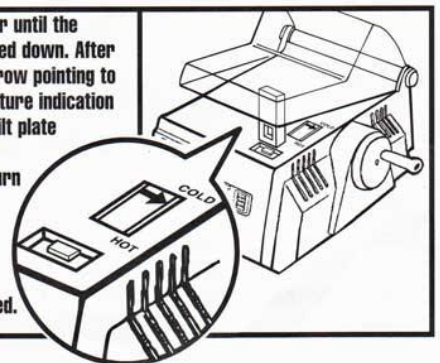

12 REMOVE THE 4 THUMBSCREWS FROM THE TILT PLATE COVER AND LIFT THE COVER OFF.

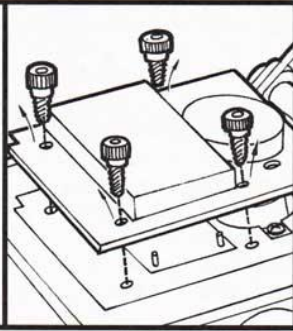

13 REMOVE THE TOP HALF OF THE MOLD, THEN THE BOTTOM HALF ALONG WITH THE MOLDED FIGURE.

* THE FIGURE MAY STILL BE WARM
-USE CARE IN HANDLING.

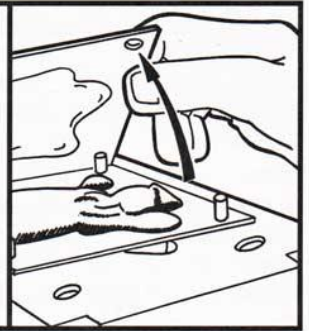

14 IF THERE IS A RUNNER CONNECTED TO YOUR FIGURE, USE THE RUNNER REMOVER ON THE END OF YOUR FINISHING BOARD TO SNAP IT OFF.

USE THE SANDING SIDE OF YOUR FINISHING BOARD TO SMOOTH ANY ROUGH SURFACES ON YOUR FIGURE. USE CAUTION WHILE FINISHING YOUR FIGURES, AS SOME OF THE ROUGH EDGES MAY BE POINTY.



15 DECORATE YOUR FIGURES WITH THE GEMS (SUPPLIED) BY PLACING THE GEMS ONTO AN ADHESIVE TAB AND PLACING THEM ONTO YOUR MOLDED FIGURES.

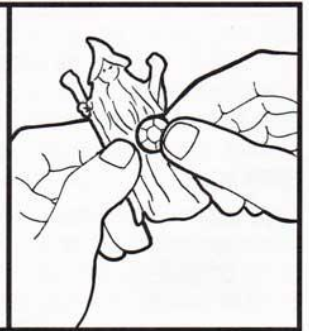

16 TURN YOUR MOLDED FIGURES INTO COOL, WEARABLE ART WITH YOUR ACCESSORIES (SUPPLIED). THE PLASTIC ACCESSORIES CONNECT TO YOUR FIGURES BY PUSHING THE POST ON THE ACCESSORIES INTO THE HOLE ON YOUR FIGURE. BE SURE TO PUSH THE POST ALL THE WAY INTO THE FIGURE FOR THE MOST PERMANENT CONNECTION. THEN YOU CAN ATTACH YOUR FIGURE TO A NECKLACE (SUPPLIED), YOUR KEYS, YOUR BOOKBAG OR BACKPACK, COAT OR BASEBALL CAPS.



YOU CAN TURN MOLDED METAL FIGURES INTO ALMOST ANYTHING. YOU CAN COLLECT 'EM AND TRADE 'EM, WEAR 'EM AND SHARE 'EM.

YOU CAN MAKE YOUR OWN METAL ARMIES ONLY WITH THE METAL MOLDER™ DIE CAST FACTORY! WHEN YOU WANT TO MOLD FIGURES AND COLLECT NEW STYLES AND THEMES, LOOK FOR THE METAL MOLDER™ MOLD PAKS COLLECTOR MOLDS AND DIE-CAST PELLET REFILLS.

We're Always Here To Help!

We know you are going to enjoy playing with your

METAL MOLDER™ DIE CAST FACTORY™ SET

If you have any questions or comments, our Customer Service Representatives will be glad to help you.

Call: 1-800-222-9060

between 9:00 am and 5:00 pm EST. Monday through Friday, or write to:

TOYMAX INC.

200 Hicks Street, Westbury N.Y. 11590

Please include the following information: Name of product, Item Number, Sales Receipt, Date of Purchase, Where Purchased and a Brief Description of Problem.

CONFORMS TO ASTM-F963-95. CONFORMS TO ASTM-D4236.
COLORS & CONTENTS MAY VARY. CAUTION: USE IN WELL VENTILATED AREA.
© 1996 TOYMAX INC. WESTBURY, N.Y. 11590 U.S.A. ALL RIGHTS RESERVED.
TM AND ® DESIGNATE TRADEMARKS OF TOYMAX INC. & TOYMAX (H.K.) LTD.

MADE IN CHINA.

SAFE AND NON-TOXIC

80001 T/2





INSTRUCTION SUPPLEMENT

YOUR METAL MOLDER™ DIE CAST FACTORY COMES WITH EVERYTHING NEEDED TO MAKE AND FINISH GREAT COLLECTIBLE METAL FIGURES. THERE ARE SOME COMMON HOUSEHOLD TOOLS AND SUPPLIES THAT CAN ALSO BE USED TO FINISH YOUR METAL CREATION...

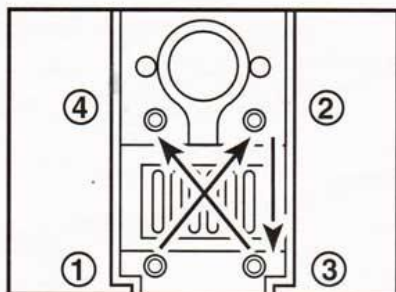

FOR BEST RESULTS, TIGHTEN ALL SCREWS INTO TILT PLATE IN NUMERICAL ORDER, MAKE SURE THEY ARE COMPLETELY TIGHTENED.



NAIL FILES (EMERY BOARDS) OR MEDIUM GRIT SANDPAPER CAN BE USED TO REMOVE FLASH OR RUNNERS FROM FIGURES.



PLIERS CAN ALSO BE USED TO BREAK OFF FLASH AND RUNNERS FROM FIGURES.

- FIGURES CAN BE PAINTED USING ANY TYPE OF MODEL PAINT OR PERMANENT MAGIC MARKERS. THIS SHOULD ONLY BE USED UNDER ADULT SUPERVISION AND BY EXPERIENCED MODEL BUILDERS.**
- TO MOUNT FIGURES PERMANENTLY TO ANY OF YOUR ACCESSORIES, YOU CAN USE ANY STANDARD WHITE GLUE.**

IF YOU HAVE ANY SUGGESTIONS ABOUT YOUR METAL MOLDER™ DIE CAST FACTORY PLEASE CALL US AT 1- 800 - 222 - 9060. WE ARE INTERESTED IN HEARING ABOUT ALL THE NEW AND EXCITING WAYS OUR CUSTOMERS ARE USING THE METAL MOLDER™ DIE CAST FACTORY. THE ONLY REAL METAL MOLDING MACHINE FOR KIDS!